



**Angular-Rate Sensor
XV-3500CB Prototype PCB
User's Guide**

Table of contents

Chapter1. Overview.....	1
1.1 Introduction.....	1
1.2 Quick Start	1
Chapter2. Hardware Description	2
2.1 Hardware components on board	2
2.2 Port Definition.....	2
2.3 Mechanical Drawing	3
Chapter3.Notice	4



Angular-Rate Sensor XV-3500CB Prototype PCB

NOTES:

Product Version : Ver 1.0

Document Version : Ver 1.0



Chapter1. Overview

1.1 Introduction

Thanks for purchasing the angular-rate sensor module of Sure Electronics. This module can help users record instant angular rate in conjunction with peripheral circuits and provide data needed for analyzing the rotation of objects. It has a wide application in intelligent control, such as automobile, sports facilities, toys and digital camera.

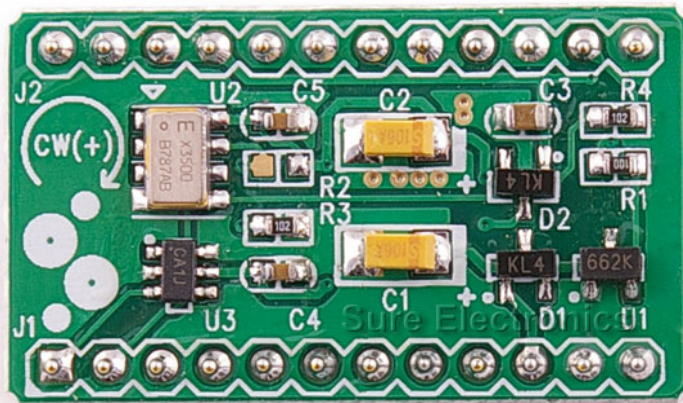

Fig 1

1.2 Quick Start

- 1 Feed this module with either +5V or +3.3V power, but not simultaneously.
 - 2 The voltage output from “ANA0” port of angular-rate sensor indicates the variation of angular rate.
 - 3 The voltage output from angular-rate sensor module can be obtained via I²C interface after analog-to-digital conversion.
 - 4 In case that users need to use this module on PCB, two strips of 12-pin holes or similar pin header sockets (Users may refer to “2.3 mechanical drawing” in “chapter 2 Hardware Description” for dimensions) shall be reserved for connection with this module. Besides, the port sequence and definitions requirement shall be met. (Users may refer to “2.2 Port Definition” in “Chapter 2 Hardware Description” for details)
-

Chapter2. Hardware Description

2.1 Hardware components on board

- (1) Angular-rate sensor: XV-3500CB chip
- (2) Analog-to-Digital chip: mcp3421 chip

2.2 Port Definition

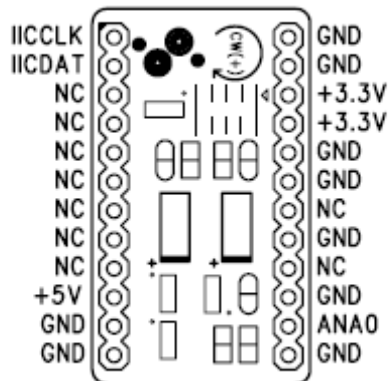

Port mark	Port description
IICCLK,IICDAT	The clock and the data end of I ² C interface
NC	No connection
+5V	+5V Power input end
GND	GND
+3.3V	This port outputs 3.3V if powered by +5V supply; or separately used as positive pole of +3.3V power supply
ANA0	Analog voltage output end of angular-rate sensor

2.3 Mechanical Drawing

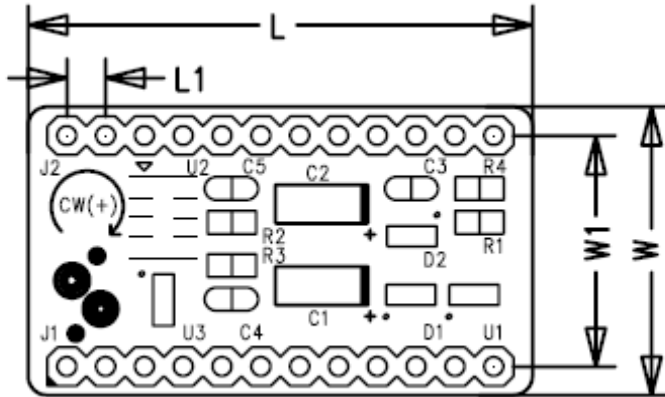

Symbol	L	L1	W	W1
Inch	1.30	0.10	0.75	0.60
mm	33.02	2.54	19.05	15.24

Chapter3.Notice

1. Parameters list of angular-rate sensor module

(1)Operating Condition

Item	Symbol	Specifications			Remarks
		Min.	Typ	Max.	
Operating Voltage	V _{DD}		5V/3.3V		GND=0V
Operating temperature	T _{OPR}	-20°C		+80°C	
Output Current	I _{ANA}	0		+100uA	Analog Voltage
Output Current	I _{I2C}	0		+10mA	I ² C interface

(2)Electrical Characteristics

Item	Symbol	Specifications			Remarks
		Min.	Typ	Max.	
Scale Factor	So		0.65mV/deg/s		
Limit Scale Factor Accuracy	Sp			±5%	Ta=+25°C
Scale Factor Temperature sensitivity	Spt			±5%	Based +25°C
Bias	Vo	Vr-50mV	Vr	Vr+50mV	Ta=+25°C
Reference Voltage	Vr	1320mV	1350mV	1380mV	If module is stable
Defection Range	I	-100deg/s		+100deg/s	
Phase Delay	Φ20		4(degree)		At 20Hz phase delay angle
Frequency Response	BW		200Hz		Phase delay angle 90°
Power Consumption	Iop		1.9mA		ANA0:No Load Condition

2. Notes on the use of I²C data and clock port

The AD readout can be obtained via I²C interface; both data and clock end are needed to connect with V_{dd} via pull-up resistor. The selection of resistance value depends on the mode of I²C interface, which are standard (100kbits/sec) and fast (400kbits/sec) ranging from 1kΩ~10kΩ. The selection range for High speed (3.4Mbits/sec) is a threshold of lower than 1kΩ.

The address bytes written into the MCP3421 is 1101000X (for both standard and fast mode) after the start bit is sent out via data cable. AD conversion value and configuration bytes can be read (while MCP 3421 is in its default setting) if “X” stands for 1. If “X” stands for 0, the next would be writing configuration bytes into MCP 3421. So AD conversion value and configuration bytes can be read. The address byte could also be 00001YYY (High speed mode). The bits YYY are unique to the High-Speed (HS) mode master. This byte is referred to as High-Speed (HS) Mode Master Code (HSMMC).

Users may refer to the related documents of MCP3421 for the operation of I²C interface, detailed time parameters, configuration of register and the calculation of AD value.

Appendix1: Schematic

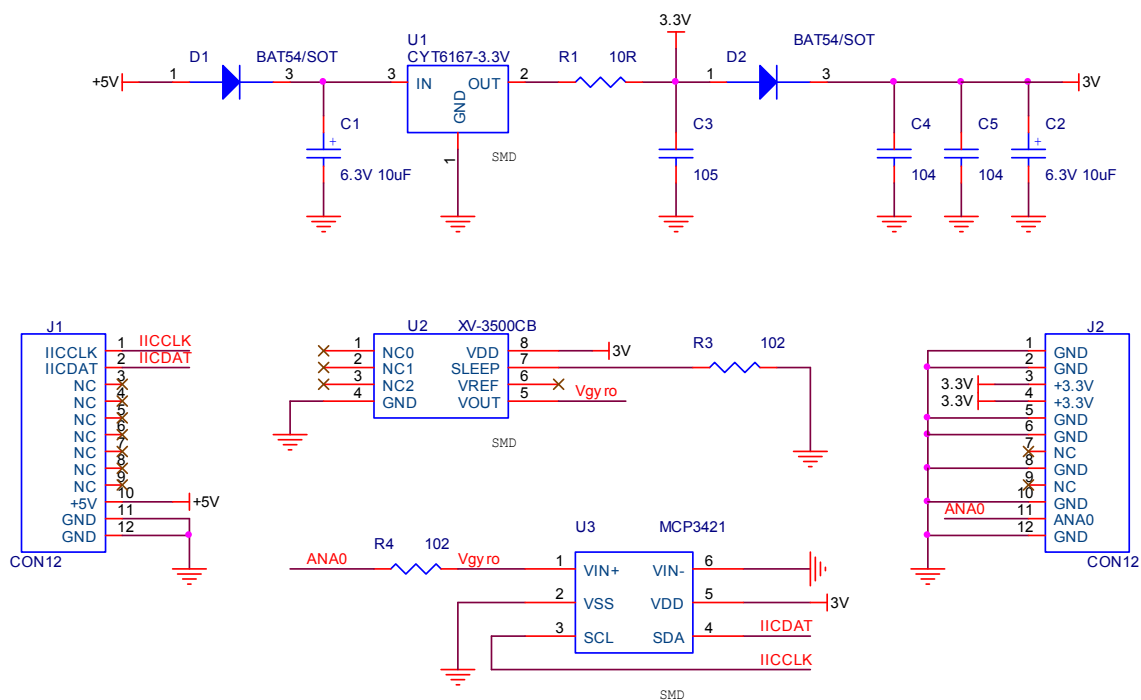

Appendix2: PCB layout

