

SkyNav SKM53 Series Ultra High Sensitivity and Low Power The Smart Antenna GPS Module

<http://www.webtronico.com>

General Description

The SkyNav SKM53 Series with embedded GPS antenna enables high performance navigation in the most stringent applications and solid fix even in harsh GPS visibility environments.

It is based on the high performance features of the MediaTek 3327 single-chip architecture, Its -165dBm tracking sensitivity extends positioning coverage into place like urban canyons and dense foliage environment where the GPS was not possible before. The 6-pin and USB connector design is the easiest and convenient solution to be embedded in a portable device and receiver like PND, GPS mouse, car holder, personal locator, speed camera detector and vehicle locator.

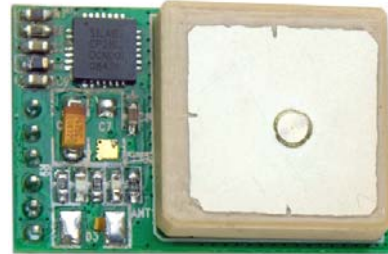

Figure 1: SKM53 series Top View

Applications

- LBS (Location Based Service)
- Vehicle navigation system
- PND (Portable Navigation Device)
- GPS mouse and Bluetooth GPS receiver
- Timing application

Features

- Ultra high sensitivity: -165dBm
- 22 tracking/66 acquisition-channel receiver
- WAAS/EGNOS/MSAS/GAGAN support
- NMEA protocols (default speed: 9600bps)
- Internal back-up battery and 1PPS output
- One serial port and USB port (option)
- Embedded patch antenna $18.2 \times 18.2 \times 4.0 \text{ mm}$
- Operating temperature range: -40 to 85°C
- RoHS compliant (Lead-free)
- Tiny form factor : $30\text{mm} \times 20\text{mm} \times 11.4\text{mm}$

Pin Assignment

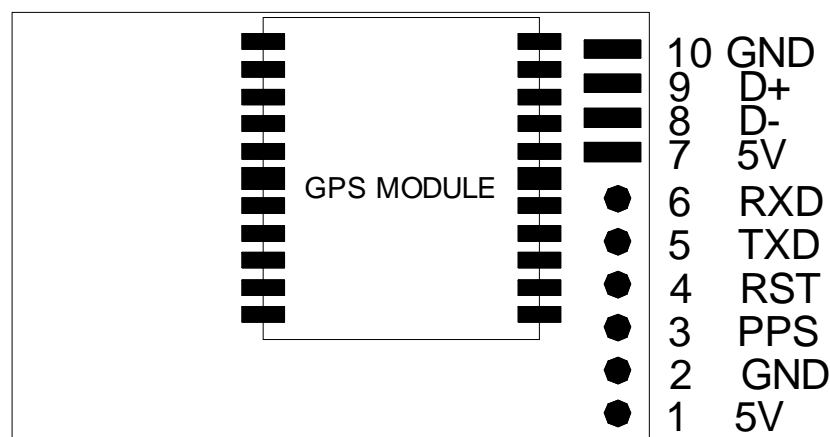

Figure 2: SKM53 Series Pin Package

Performance Specification

Parameter	Specification	
GPS receiver		
Receiver Type	L1 frequency band, C/A code, 22 Tracking / 66 Acquisition-Channel	
Sensitivity	Tracking Acquisition	-165dBm -148dBm
Accuracy	Position Velocity Timing (PPS)	3.0m 3D RMS without SA 0.1m/s without SA 60ns RMS
Acquisition Time	Cold Start Warm Start Hot Start Re-Acquisition	36s 33s 1s <1s
Power Consumption	Tracking Acquisition Sleep/Standby	<30mA @3.0V 40mA @3.0V TBD
Navigation Data Update Rate	1Hz	
Operational Limits	Altitude Velocity Acceleration	Max 18,000m Max 515m/s Less than 4g
Antenna Specifications		
Outline Dimension	18.2 x 18.2 x 4.0 mm	
Center Frequency	1575 ± 3 MHz	
Bandwidth	10 MHz min	
Impedance	50 Ω	
Axial Ratio	3 dB max	
Polarization	RHCP	
Mechanical requirements		
Dimension	30mm x20mm x 11.4mm	
Weight	9g	
Power consumption		
VCC	5V ±5%	
Current	55mA(typical)	
Environment		
Operating temperature	40 ~ +85 °C (w/o backup battery)	
Storage temperature	40 ~ +125 °C	
Humidity	≦95%	

Hardware Interfaces Configuration

Power Supply: Regulated power for the SKM53 series is required. The input voltage V_{cc} should be 5V, current is no less than 150mA. Suitable decoupling must be provided by external decoupling circuitry(10uF and 1uF). It can reduce the Noise from power supply and increase power stability.

UART Ports: The module supports one full duplex serial channels UART. The serial connections are at 2.85V LVTTTL logic levels, if need different voltage levels, use appropriate level shifters. the data format is however fixed: X, N, 8, 1, i.e. X baud rate, no parity, eight data bits and one stop bit, no other data formats are

supported, LSB is sent first. The modules default baud rate is set up 9600bps. The RXD0 & TXD0 recommended to pull up (10K Ω). It can increase the stability of serial data.

USB Ports: The module uses single-chip USB to UART bridge by Silicon CP2102, It is a USB 2.0 compliant full-speed device with integrated transceiver. Before using it, please install the appropriate driver.

GPS Status: GPS Status can be connected to a LED to indicate the status of GPS signal. Lights indicate GPS not fix and flashing indicate fix.

Pin Description

Pin No.	Pin name	I/O	Description	Remark
UART Port				
1	5V	P	Module Power Supply	VCC:5V \pm 5%
2	GND	G	Module Power Ground	Reference Ground
3	PPS	O	Time pulse Signal (Default 200ms pulse/sec)	Leave Open in not used
4	RST	I	Module Reset (Active Low Status)	
5	TXD	I	TTL:VOH \geq 0.75 *VDD VOL \leq 0.25VDD	Pull up if not used
6	RXD	O	TTL:VIH \geq 0.7 *VDD VIL \leq 0.3 *VDD	Leave Open in not used
USB Port				
7	5V	P	USB Power Supply	
8	D-	I/O	Data-	
9	D+	I/O	Data+	
10	GND	G	USB Power Supply	

Ordering Information

SKM53S: UART Port Interface

SKM53U: USB Port Interface

Mechanical Specification

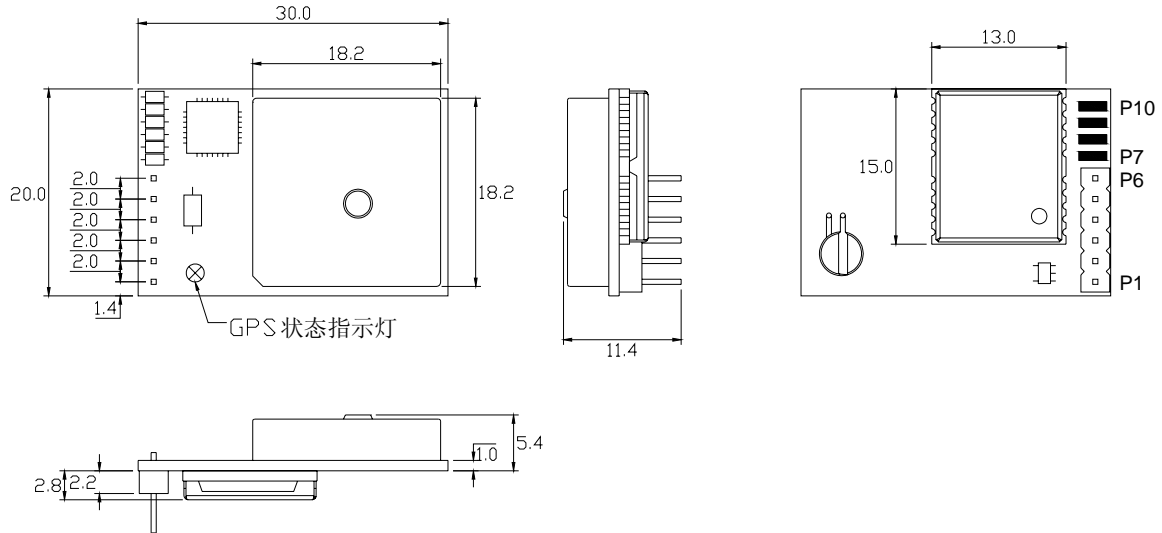

Figure 3: SKM53 Series Dimensions

Software Protocol

NMEA 0183 Protocol

The NMEA protocol is an ASCII-based protocol. Records start with a \$ and with carriage return/line feed. GPS specific messages all start with \$GPxxx where xxx is a three-letter identifier of the message data that follows. NMEA messages have a checksum, which

allows detection of corrupted data transfers.

The SkyNav SKM53 series supports the following NMEA-0183 messages: GGA, GLL, GSA, GSV, RMC, VTG, ZDA.

Table 1: NMEA-0183 Output Messages

NMEA Record	DESCRIPTION
GGA	Global positioning system fixed data
GLL	Geographic position—latitude/longitude
GSA	GNSS DOP and active satellites
GSV	GNSS satellites in view
RMC	Recommended minimum specific GNSS data
VTG	Course over ground and ground speed
ZDA	Time and Date

GGA-Global Positioning System Fixed Data

Table 2 contains the values of the following example:

\$GPGGA, 083559.00,3723.2475,N, 12158.3416,W, 1,07,1.0,9.0,M, ,M, ,0000*18

Table 2: GGA Data Format

Name	Example	Units	Description
Message ID	\$GPGGA		GGA protocol header
UTC Time	083559.00		hhmmss.sss
Latitude	3723.2457		ddmm.mmmm
N/S indicator	N		N=north or S=south
Longitude	12158.3416		ddmm.mmmm
E/W Indicator	W		E=east or W=west
Position Fix Indicator	1		See Table 2-1
Satellites Used	07		Range 00 to 12
HDOP	1.0		Horizontal Dilution of Precision
MSL Altitude	9.0	meters	Altitude above mean seal level
Units	M	meters	
Geoids Separation		meters	Separation from Geoids can be bank
Units	M	meters	
Age of Diff.Corr.		second	Null fields when DGPS is not Used
Diff.Ref.Station ID	0000		Null fields when DGPS is not Used
Checksum	*18		
<CR> <LF>			End of message termination(ASCII 13, ASCII 10)

Table 2-1: Position Fix Indicators

Value	Description
0	Fix not available or invalid
1	GPS SPS Mode, fix valid
2	Differential GPS, SPS Mode, fix valid
3	GPS PPS Mode, fix valid

GLL-Geographic Position – Latitude/Longitude

Table 3 contains the values of the following example:

\$GPGLL , 3723.2475, N,12158.3416, W, 083559.00, A*2C.

Table 3: GLL Data Format

Name	Example	Units	Description
Message ID	\$GPGLL		GLL protocol header
Latitude	3723.2475		Ddmm.mmmm
N/S Indicator	N		N=north or S=south
Longitude	12158.3416		Ddmm.mmmm
E/W Indicator	W		E=east or W=west
UTC Time	083559.00		Hhmmss.sss
Status	A		A=data valid or V=data not valid

Checksum	*2C		
<CR> <LF>			End of message termination(ASCII 13, ASCII 10)

GSA-GNSS DOP and Active Satellites

Table 4 contains the values of the following example:
 \$GPGSA , A, 3, 07, 02, 26,27, 09, 04,15, , , , , , 1.8,1.0,1.5*33.

Table 4: GSA Data Format

Name	Example	Units	Description
Message	\$GPGSA		GSA protocol header
Mode 1	A		See Table 4-2
Mode 2	3		See Table 4-1
Satellite Used	07		Sv on Channel 1
Satellite Used	02		Sv on Channel 2
...
Satellite Used			Sv on Channel 12
PDOP	1.8		Position Dilution of Precision
HDOP	1.0		Horizontal Dilution of Precision
VDOP	1.5		Vertical Dilution of Precision
Checksum	*33		
<CR> <LF>			End of message termination(ASCII 13, ASCII 10)

Table 4-1: Mode 1

Value	Description
1	Fix not available
2	2D
3	3D

Table 4-2: Mode 2

Value	Description
M	Manual-forced to operate in 2D or 3D mode
A	Automatic-allowed to automatically switch 2D/3D

GSV-GNSS Satellites in View

Table 5 contains the values of the following example:
 \$GPGSV , 2, 1, 07, 07, 79, 048, 42, 02, 51,062, 43, 26, 36,256, 42, 27, 27, 138,42*71
 \$GPGSV , 2, 2, 07, 09, 23,313, 42, 04, 19, 159, 41, 15,12,041, 42*41.

Table 5: GGA Data Format

Name	Example	Units	Description
Message ID	\$GPGSV		GSV protocol header
Number of	2		Range 1 to 3

Message			
Message Number	1		Range 1 to 3
Satellites in View	07		
Satellite ID	07		Channel 1(Range 1 to 32)
Elevation	79	degrees	Channel 1(Maximum 90)
Azinmuth	048	degrees	Channel 1(True, Range 0 to 359)
SNR(C/NO)	42	dBHz	Range 0 to 99,null when not tracking
...			...
Satellite ID	27		Channel 4(Range 1 to 32)
Elevation	27	degrees	Channel 4(Maximum 90)
Azimuth	138	degrees	Channel 4(True, Range 0 to 359)
SNR(C/NO)	42	dBHz	Range 0 to 99, null when not tracking
Checksum	*71		
<CR> <LF>			End of message termination(ASCII 13, ASCII 10)

Depending on the number of satellites tracked multiple messages of GSV data may be required.

RMC-Recommended Minimum Specific GNSS Data

Table 6 contains the values of the following example:

\$GPRMC, 083559.00, A, 3723.2475, N, 12158.3416, W, 0.13, 309.62, 120598, , *10

Table 6: RMC Data Format

Name	Example	Units	Description
Message ID	\$GPRMC		RMC protocol header
UTC Time	083559.00		hhmmss.sss
Status	A		A=data valid or V=data not valid
Latitude	3723.2475		ddmm.mmmm
N/S Indicator	N		N=north or S=south
Longitude	12158.3416		Ddmm.mmmm
E/W Indicator	W		E=east or W=west
Speed Over Ground	0.13	Knots	
Course Over Ground	309.62	Degrees	True
Date	120598		Dummy
Magnetic variation		Degrees	Not used
E/W indicator			Not used
Mode			Only NMEA0183 version 3.00 output
Checksum	*10	hexadecimal	
<CR> <LF>			End of message termination(ASCII 13, ASCII 10)

VTG-Course Over Ground and Ground Speed

Table 7 contains the values of the following example:

\$GPVTG, 309.62, T, ,M, 0.13, N, 0.2, K*6E

Table 7: VTG Data Format

Name	Example	Units	Description
Message ID	\$GPVTG		VTG protocol header
Course	309.62	Degrees	Measured heading
Reference	T		True
Course		Degrees	Measured heading
Reference	M		Magnetic
Speed	0.13	Knots	Measured horizontal speed
Units	N		Knots
Speed	0.2	Km/hr	Measured horizontal speed
Units	K		Kilometer per hour
Checksum	*6E		
<CR> <LF>			End of message termination

ZDA-Date and Time

Table 8 contains the values of the following example:

\$GPZDA, 082710.00,04,07,2002,00,00*60

Name	Example	Units	Description
Message ID	\$GPZDA		ZDA protocol header
UTC Time	082710.00		hhmmss.sss
Day	04		UTC time: day (01 ... 31)
Month	07		UTC time: month (01 ... 12)
Year	2002		UTC time: year (4 digit year)
local zone hours	00		Not supported (fixed to 00)
local zone minutes	00		Not supported (fixed to 00)
Checksum	*60		
<CR> <LF>			End of message termination

How to Reach Us:

Skylab M&C Technology Co., Ltd.

Address: Room.801, Bldg.211, Terra Industrial Park, Futian District, Shenzhen

Phone: 86-755 8340 8210 (Sales Support)

Phone: 86-755 8340 8130 (Technical Support)

Fax: 86-755-8340 8560

E-Mail: sales@skylab.com.cn

©Copyright 2008 SkyLab M&C Co., Ltd, All Right Reserved

The information contained herein is subject to change without notice.